

# Forged Steel Blow-Off Valve

Straightway Type

Model # 6YBWFS2

600# Socket Weld Ends

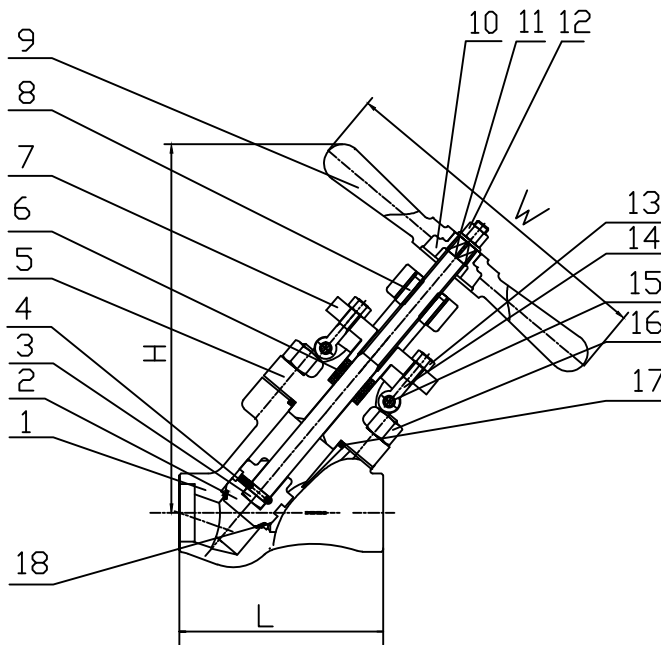

Davis blow-off valves comply with the following applicable specifications: ANSI B16.34, ANSI B16.11, ANSI B1.20.2, API 602, MSS SP-84: Tested to API 598

**Class 600**

**Fig# 6YBWFS2**

NO.	NAME	MATERIAL
1	BODY	A105
2	DISC	F6+Stellite
3	STEM	F6
4	BALL	F304
5	BONNET	A105
6	PACKING	Soft Grafoil with S/Steel
7	GLAND FLANGE	WCB
8	STEM NUT	Bronze
9	HANDLE	Ductile Iron
10	IMPACT	Ductile Iron
11	GASKET	A29 1035
12	NUT	A194-2H
13	EYE NUT	A194-2H
14	EYE BOLT	A193-B7
15	PIN	A29 1035
16	BOLT	A193-B7
17	GASKET	304+Graphite
18	SEAT	105+Stellite

NPS	inch	1-1/2	2
	mm	40	50
L	inch	6.7	8
	mm	171	203
W	inch	11	11
	mm	280	280
H	inch	12.6	13.8
	mm	320	350
Weight	lbs	27	38
	kgs	12.3	17.3

Basic Steam Rating - 600 lb. at 850 F  
 Max Boiler Drum Pressure - 970 psi  
 Max Non-Shock - 1440 lb. at 100 F