

WCB Steel Angle Stop Check

Model # 403ASC
Class 300 (10" - 12")

FEATURES:

- These valves comply with applicable requirements of Section 1, Power Boilers, ASME Boiler and Pressure Vessel Code
- CA-15 seat and disc with stellite overlay and CA-15 stem for longer service life
- Hammer blow handwheel

Also available as a standard angle globe valve

Designed to ANSI B16.34,
tested to API 598.
Flanges to ANSI B16.5

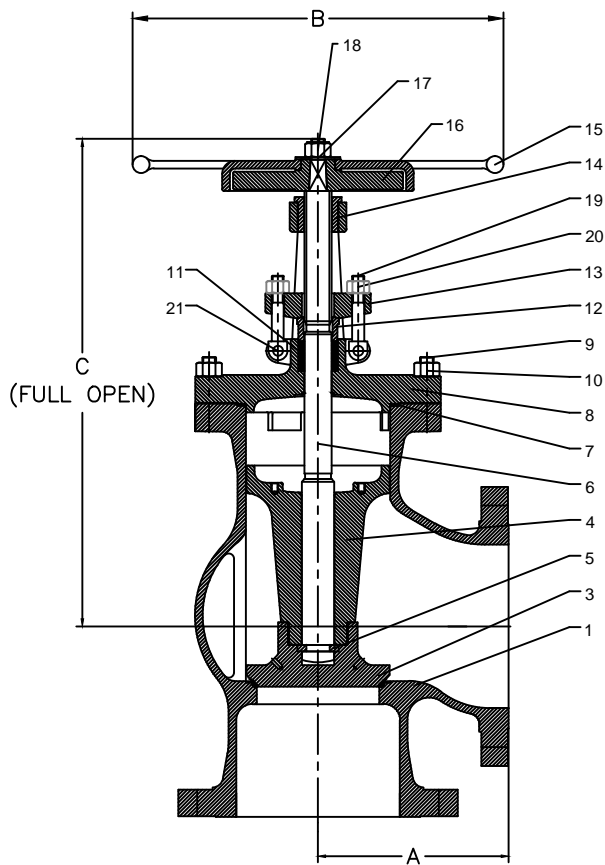

NO.	PART NAME	A 216-WCB
1	BODY	A 216-WCB
2	SEAT	ST6
3	DISC	CA-15+ST6
4	DISC RETAINER	A 217-CA 15
5	STEM COLLAR	A 276-304
6	STEM	A 479-410-1
7	SW GASKET	SS 316+GRAPHITE
8	BONNET	WCB
9	STUD	A 193-B7
10	HEAVY HEX NUT	A 194-2H
11	GLAND PACKING	GRAPHITE WITH INCONEL
12	GLAND BUSH	A 276-410
13	GLAND FLANGE	A 216-WCB
14	STEM NUT	AL BRONZE (B 148-Gr D)
15	HAND WHEEL	A 216-WCB/DUCTILE IRON
16	HAMMER	A 216-WCB/DUCTILE IRON
17	WASHER	A 276-304
18	NYLOCK NUT	A 276-304
19	GLAND BOLT	A 307B
20	HEAVY HEX NUT	A 194-2H
21	GROOVE PIN	C 40

SIZE	INCH	10	12
	MM	250	300
A	INCH	12.25	14.0
	MM	311.5	355.6
B	INCH	20	27
	MM	508	686
C	INCH	34.0	38.5
	MM	864	978
Wgt	Lbs	745	1168

