

# All Iron Swing Check

Model # 12FCHIZ

Class 125 (2" to 24")

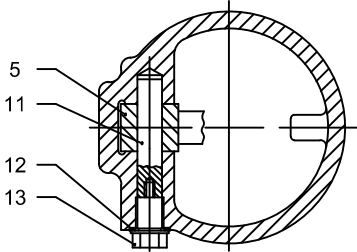

**STANDARD:**

Design according to MSS SP-71  
 Pressure/Temperature Rating: ANSI B16.1  
 Face to Face Dimensions: ANSI B16.10  
 End Flange Dimensions: ANSI B16.1  
 Wall thickness: ANSI B16.1  
 Valves Tested According to API 598

**WORKING PRESSURE:**

2" to 12" - 125psi Steam, Basic Rating 200psi Cold Working Pressure  
 14" to 24" - 100psi Steam, Basic Rating 150psi Cold Working Pressure

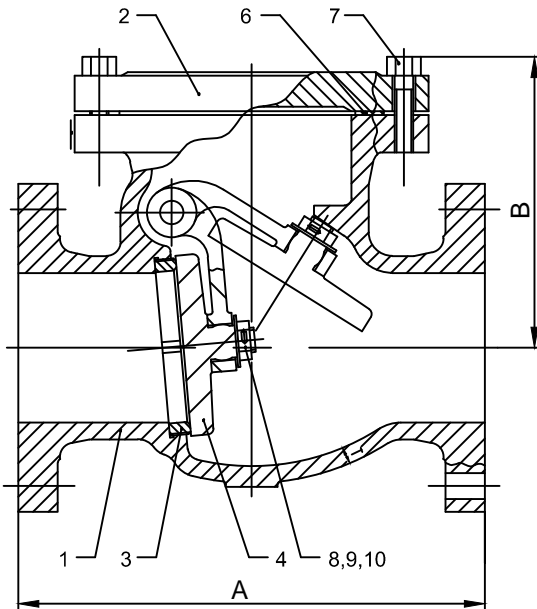

NO.	PART NAME	MATERIAL
1	BODY	ASTM A126-B
2	BONNET	ASTM A126-B
3	SEAT RING	DUCTILE IRON
4	DISC	CAST IRON
5	HINGE	DUCTILE IRON
6	GASKET	GRAPHITE
7	BOLTS	ASTM A307-B
8	NUTS	STEEL
9	WASHER	STEEL
10	PIN	STAINLESS STEEL
11	HINGE PIN	STEEL
12	GASKET	BRASS ASTM B16
13	PLUG	STEEL

SIZE	INCH	2	2-1/2	3	4	5	6	8	10	12	14	16	18	20	24
	MM		50	65	80	100	130	150	200	250	300	350	400	450	500
A	INCH	8	8.5	9.5	11.5	13	14	19.5	24.5	27.5	31	36	38	42	46
	MM	203	216	241	292	330	356	495	622	698	787	914	965	1067	1169
B	INCH	6	6.38	6.13	7	8.88	11.13	13	15.13	17	19	21.25	17.19	19.25	25.88
	MM	152	162	156	180	226	282	331	384	434	485	541	437	489	657
Weight	lbs	24	37	44	75	120	128	229	481	701	875	1413	1727	2596	3520
	kgs	11	17	20	34	54	58	104	218	318	397	641	783	1178	1597

