

# Cast Iron Swing Check

Model # 12FCHZ-LW

Class 125 (2" to 24")

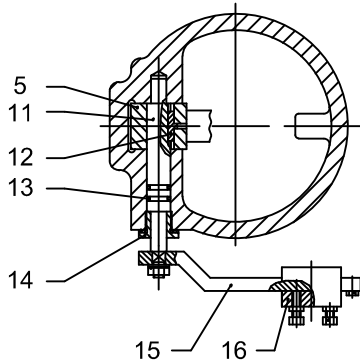

**STANDARD:**

Design according to MSS SP-71  
 Pressure/Temperature Rating: ANSI B16.1  
 Face to Face Dimensions: ANSI B16.10  
 End Flange Dimensions: ANSI B16.1  
 Wall thickness: ANSI B16.1  
 Valves Tested According to API 598

**WORKING PRESSURE:**

2" to 12" - 125psi Steam, Basic Rating 200psi Cold Working Pressure  
 14" to 24" - 100psi Steam, Basic Rating 150psi Cold Working Pressure

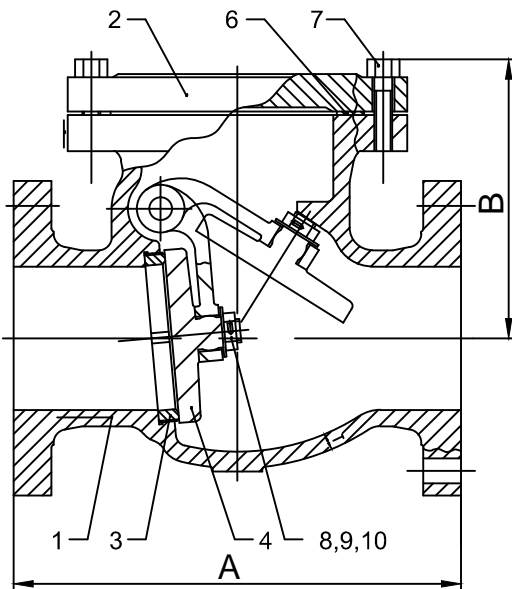

NO.	PART NAME	MATERIAL
1	BODY	ASTM A126-B
2	BONNET	ASTM A126-B
3	SEAT RING	BRONZE ASTM B62
4	DISC	DUCTILE IRON + BRONZE
5	HINGE	DUCTILE IRON
6	GASKET	GRAPHITE
7	BOLTS	ASTM A307-B
8	NUTS	BRASS ASTM B16
9	WASHER	BRASS ASTM B16
10	PINS	STAINLESS STEEL
11	HINGE PINS	STAINLESS STEEL
12	KEY	STAINLESS STEEL
13	O-RING	NBR
14	GLAND	STEEL
15	LEVER	STEEL
16	WEIGHT	STEEL

SIZE	INCH	2	2-1/2	3	4	5	6	8	10	12	14	16	18	20	24
	MM	50	65	80	100	130	150	200	250	300	350	400	450	500	600
A	INCH	8	8.5	9.5	11.5	13	14	19.5	24.5	27.5	31	36	38	42	46
	MM	203	216	241	292	330	356	495	622	698	787	914	965	1067	1169
B	INCH	6	6.38	6.13	7	8.88	11.13	13	15.13	17	19	21.25	17.19	19.25	25.88
	MM	152	162	156	180	226	282	331	384	434	485	541	437	489	657
Weight	lbs	30	43	55	86	130	139	240	516	752	829	1148	1727	2596	3520
	kgs	14	20	25	39	59	63	109	234	341	376	521	783	1178	1597

