

150# Cast Steel Flanged Angle Valve 2" - 12"

Fig# 15FANW

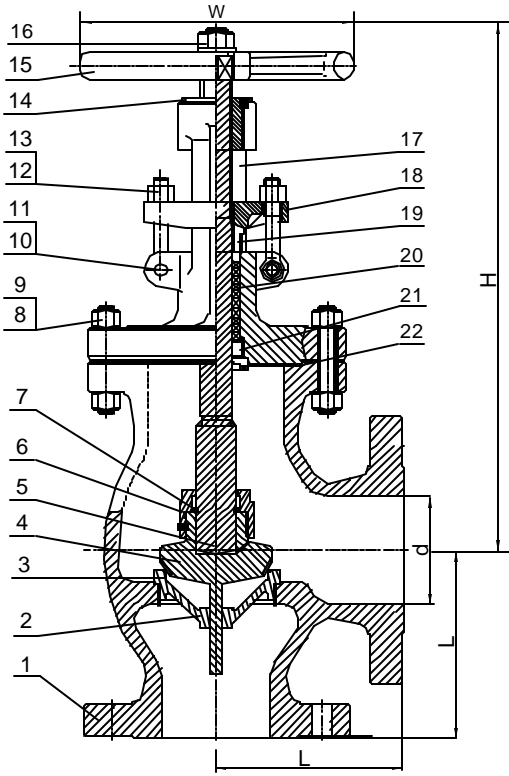

N0.	Part Name	Material
1	Body	A216 WCB
2	Disc Guide	A216 WCB
3	Seat Ring	A105 + HF
4	Disc	CR 13
5	Stem	CR 13
6	Disc Cover	CR 13
7	Ring	CR 13
8	Bolt	A193-B7
9	Nut	A194-2H
10	Pin	Steel
11	Keeper Pin	A570 Gr.A
12	Eye Nut	A194-2H
13	Eye Bolt	A193-B7
14	Yoke Bushing	Ductile Ni-Resist
15	Handwheel	Ductile Iron
16	Handwheel Nut	Steel
17	Bonnet	A216 WCB
18	Gland Flange	A216 WCB
19	Packing Gland	CR 13
20	Packing	Graphite with SS
21	Back Seat	CR 13
22	Gasket	Spiral Wound SS/Graphite

Davis cast steel valves comply with the following applicable specifications:
ANSI B16.10, ANSI B16.5, API 6D
Tested to API 598

Working Pressure: 285 WOG
Body Testing Pressure: 428 psi
Seat Testing Pressure: 314 psi
Air Testing Pressure: 80 psi

SIZE (d)	INCH	2	2½	3	4	5	6	8	10	12	
	MM		50	65	80	100	125	150	200	250	300
L	INCH		4	4.25	4.75	5.75	7	8	9.75	12.25	13.75
	MM		102	108	121	146	178	203	248	311	349
H	INCH		13.8	15	15.6	19.3	19.9	20.9	26.2	30	37
	MM		350	381	396	490	505	531	665	762	940
W	INCH		9.84	9.84	9.84	11.81	11.81	13.78	15.72	17.72	22.05
	MM		250	250	250	300	300	350	399	450	560
Weight	lbs		48	64	92	141	169	231	339	634	1115
	kgs		22	29	42	64	77	105	154	288	507

