

300# Cast Steel Flanged Angle Valve 2" - 8"

Fig# 30FANW

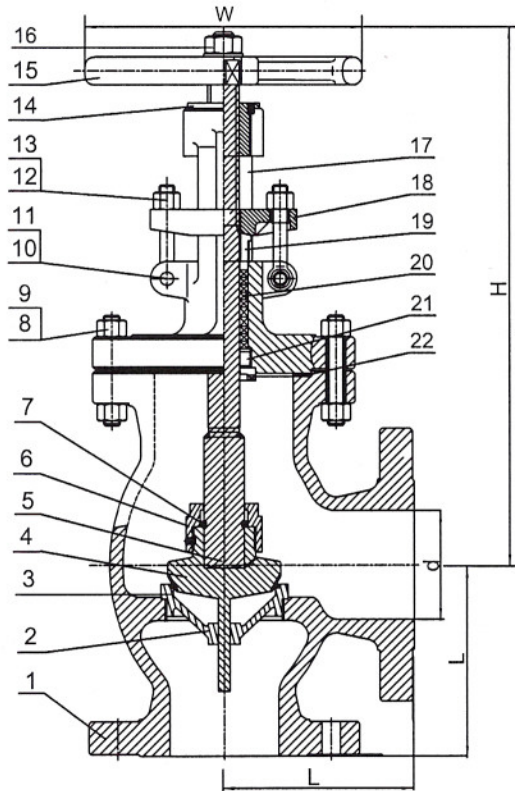

NO.	Part Name	Material
1	Body	A216 WCB
2	Disc Guide	A216 WCB
3	Seat Ring	A105 + HF
4	Disc	CR 13
5	Stem	CR 13
6	Disc Cover	CR 13
7	Ring	CR 13
8	Bolt	A193-B7
9	Nut	A194-2H
10	Pin	Steel
11	Keeper Pin	A570 Gr.A
12	Eye Nut	A194-2H
13	Eye Bolt	A193-B7
14	Yoke Bushing	Ductile Ni-Resist
15	Handwheel	Ductile Iron
16	Handwheel Nut	Steel
17	Bonnet	A216 WCB
18	Gland Flange	A216 WCB
19	Packing Gland	CR 13
20	Packing	Graphite with SS
21	Back Seat	CR 13
22	Gasket	Spiral Wound SS/Graphite

Davis cast steel valves comply with the following applicable specifications:
ANSI B16.10, ANSI B16.5, API 6D
Tested to API 598

Working Pressure: 740 WOG
Body Testing Pressure: 1110 psi
Seat Testing Pressure: 814 psi
Air Testing Pressure: 80 psi

SIZE	INCH	2	2½	3	4	5	6	8
(d)	MM	50	65	80	100	125	150	200
L	INCH	5.25	5.75	6.25	7	7.87	8.75	11
	MM	133	146	159	178	200	222	279
H	INCH	13.6	17	17.5	21.9	22.3	24.2	35.3
	MM	345	432	445	556	566	615	897
W	INCH	7.87	9.84	9.84	13.78	13.78	15.75	19.69
	MM	200	250	250	350	350	400	500
Weight	lbs	68	95	125	189	286	370	616
	kgs	31	43	57	86	130	168	280

 **Davis Valve**