

Cast Steel Globe Valve

Class 1500 Flanged (2" to 8") - 150FGLW

Class 1500 Butt Weld (2" to 8") - 150BGLW

| NO. | PART NAME | MATERIAL |
|-----|---------------|--------------------------|
| 1 | BODY | A216 WCB |
| 2 | SEAT RING | A105+HF |
| 3 | DISC | WCB+F6 |
| 4 | THRUST PLATE | A276 430 |
| 5 | DISC COVER | SS-410 |
| 6 | STEM | A182 F6 |
| 7 | GASKET | Spiral Wound SS/Graphite |
| 8 | BONNET | A216 WCB |
| 9 | BOLT | A193 B7 Steel |
| 10 | NUT | A194 2H Steel |
| 11 | PIN | A29 1035 Steel |
| 12 | GLAND | A216 WCB |
| 13 | EYE BOLT | A193 B7 Steel |
| 14 | NUT | A194 2H Steel |
| 15 | STEM NUT | D-2 Ductile Iron |
| 16 | GASKET | SS-410 |
| 17 | NUT | A29 1035 Steel |
| 18 | HANDWHEEL | Ductile Iron |
| 19 | SCREW | A29 1035 Steel |
| 20 | PACKING GLAND | SS-410 |
| 21 | PACKING | Graphite |
| 22 | DISTANCE RING | SS-410 |
| 23 | BACK SEAT | SS-410 |

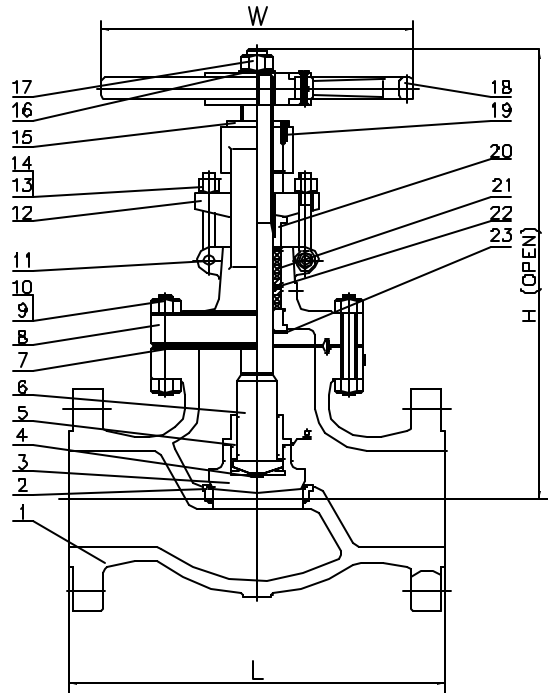

Davis cast steel valves comply with the following applicable specifications: ANSI B16.10, ANSI B16.5, API 600: Tested to API 598

Working Pressure: 3705 WOG
 Body Testing Pressure: 5560 psi
 Seat Testing Pressure: 4075 psi
 Air Testing Pressure: 80 psi

| NPS | in | 2 | 2-1/2 | 3 | 4 | 6 | 8 |
|----------------|----|-------|-------|-------|-------|-------|-------|
| | d | mm | 47 | 57 | 70 | 92 | 136 |
| L (RF & BW) | in | 14.5 | 16.5 | 18.5 | 21.5 | 27.75 | 32.75 |
| | mm | 368 | 419 | 470 | 546 | 705 | 832 |
| H (open) | in | 16.73 | 19.76 | 27.24 | 35.71 | 39.96 | 45.06 |
| | mm | 592 | 660 | 692 | 907 | 1015 | 1145 |
| W | in | 13.78 | 15.75 | 17.72 | 18.11 | 24.02 | 24.02 |
| | mm | 350 | 400 | 450 | 460* | 610* | 610* |
| WT (lbs) | RF | 247 | 311 | 503 | 741 | 1812 | 1587 |
| | BW | 185 | 254 | 403 | 611 | 1576 | 1356 |

* Manual gear operator is recommended.

