

# Cast Steel Gate Valve

Class 1500 Flanged (2" to 16") - 150FGAW

Class 1500 Butt Weld (2" to 16") - 150BGAW

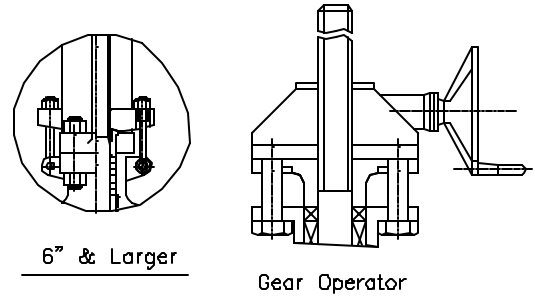

NO.	PART NAME	MATERIAL
1	BODY	A216 WCB
2	SEAT	A105+HF
3	WEDGE	WCB+F6
4	STEM	A182 F6
5	GASKET	Spiral Wound SS/Graphite
6	BONNET	A216 WCB
7	BACK SEAT	A276 410
8	PACKING	Graphite
9	DISTANCE RING	A276 410
10	PACKING GLAND	A276 410
11	GLAND	A216 WCB
12	STEM NUT	D-2 Ductile Iron
13	GLAND NUT	A29 1035 Steel
14	LOCK NUT	A29 1035 Steel
15	HANDWHEEL	Ductile Iron
16	GREASE FITTING	Steel
17	EYE BOLT	A193 B7 Steel
18	EYE NUT	A194 2H Steel
19	PIN	A29 1035 Steel
20	BOLT	A193 B7 Steel
21	NUT	A194 2H Steel

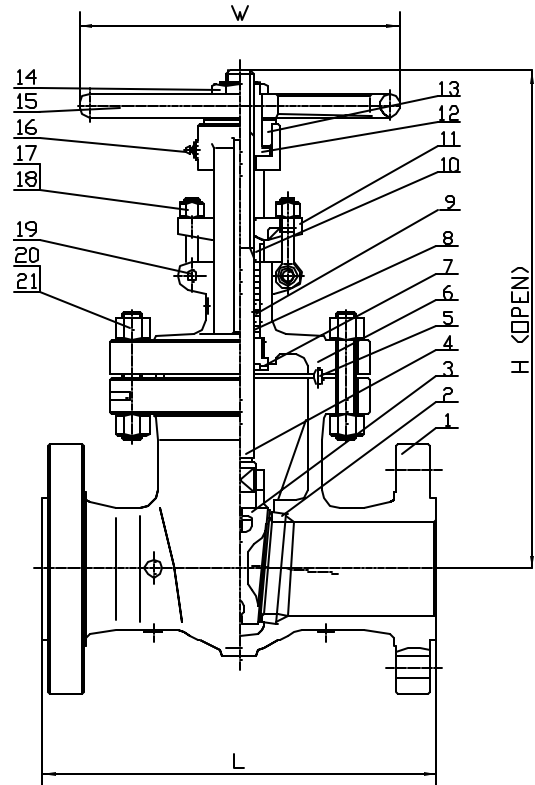

Davis cast steel valves comply with the following applicable specifications: ANSI B16.10, ANSI B16.5, API 600: Tested to API 598

Working Pressure: 3705 WOG Body Testing Pressure: 5560 psi  
 Seat Testing Pressure: 4075 psi Air Testing Pressure: 80 psi

NPS d	in	2	2-1/2	3	4	6	8	10	12	14	16
	mm	47	57	70	92	136	178	222	263	289	330
L (RF & BW)	in	14.5	16.5	18.5	21.5	27.75	32.75	39	44.5	48.5	54.5
	mm	368	419	470	546	705	832	991	1130	1257	1384
H (open)	in	22.6	27.56	31.73	34.92	42.48	53.94	59.84	65	76.57	88.58
	mm	574	700	806	887	1079	1370	1520	1651	1945	2250
W	in	13.78	15.75	17.72	22.05	12.01	24.02	29.92	29.92	29.92	29.92
	mm	350	400	450	560	305*	610*	760*	760*	760*	760*
WT (Lbs)	RF	258	386	529	743	1499	2707	5022	7187	9039	13140
	BW	205	317	408	628	1287	2156	4387	6283	7319	10781

\* Manual gear operator is recommended.

