

Ball Valve Standard Port

Model # 15FBA-SWFR (WCB)

Model # 15FBA-SFFR (316SS)

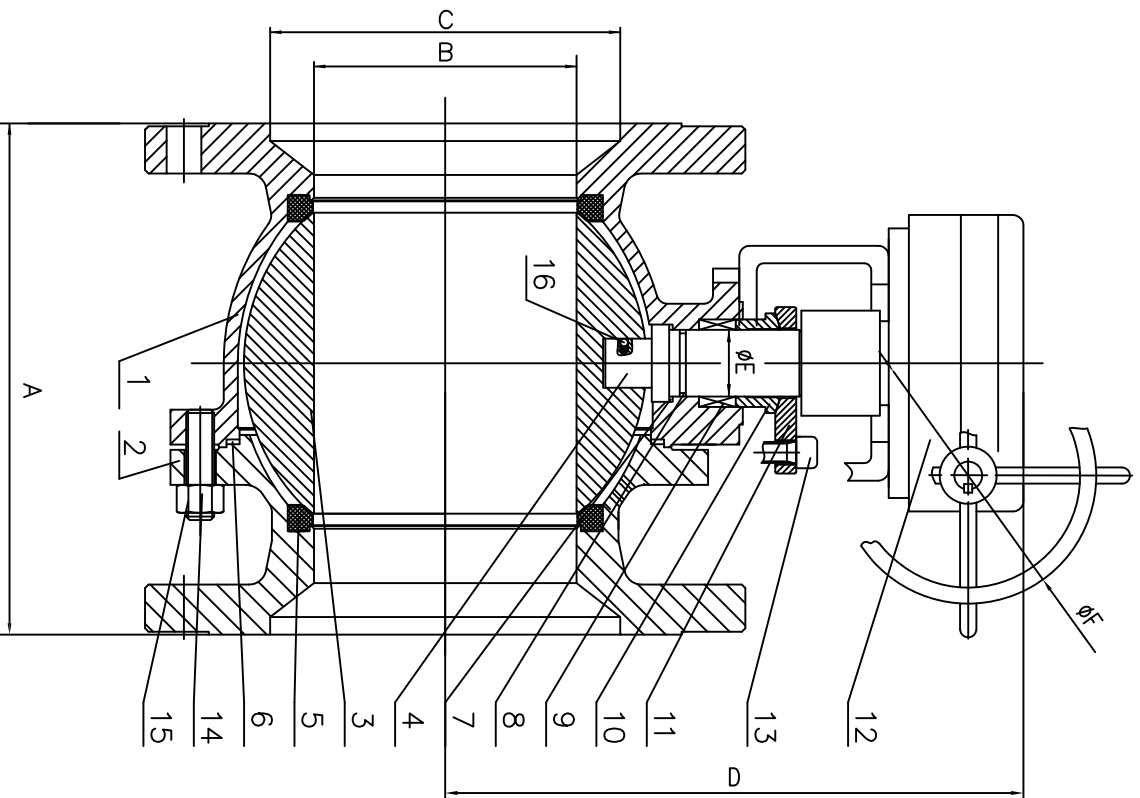

Designed to ASME B16.34/API 608
 Face to Face to ASME/ANSI B16.10
 Flange Dimensions to ASME/ANSI B16.5
 Tested to API 598
 API 607 Fire Safe
 ISO 5211 Mounting Pad

No.	Part	WCB	316SS
1	Body	WCB	CF8M
2	Bonnet	WCB	CF8M
3	Ball	316SS	316SS
4	Stem	316SS	316SS
5	Seat	RP TFE	RP TFE
6	Gasket	316+graphite	316+graphite
7	Gasket	PTFE	PTFE
8	O-Ring	VITON	VITON
9	Packing	Graphite	Graphite/PTFE
10	Packing Gland	A105	304SS
11	Gland	WCB	CF8
12	Gear	Assembly	Assembly
13	Inner Hexagon Screw	A193 B7	A193 B8
14	Stud	A193 B7	A193 B8
15	Nut	A194 2H	A194, 8
16	Anti-Static	SS	SS

Size in	A	B	C	D	E	F	Wt lbs
10	13.0	8.0	10.0	16.3	1.6	18.1	4.41
12	14.0	10.0	12.0	18.0	2.0	23.6	7.05

Davis Valve

Rev 2020