

Ball Valve Full Port

Model # 30FBA-FWFR (WCB)

Model # 30FBA-FFFR (316SS)

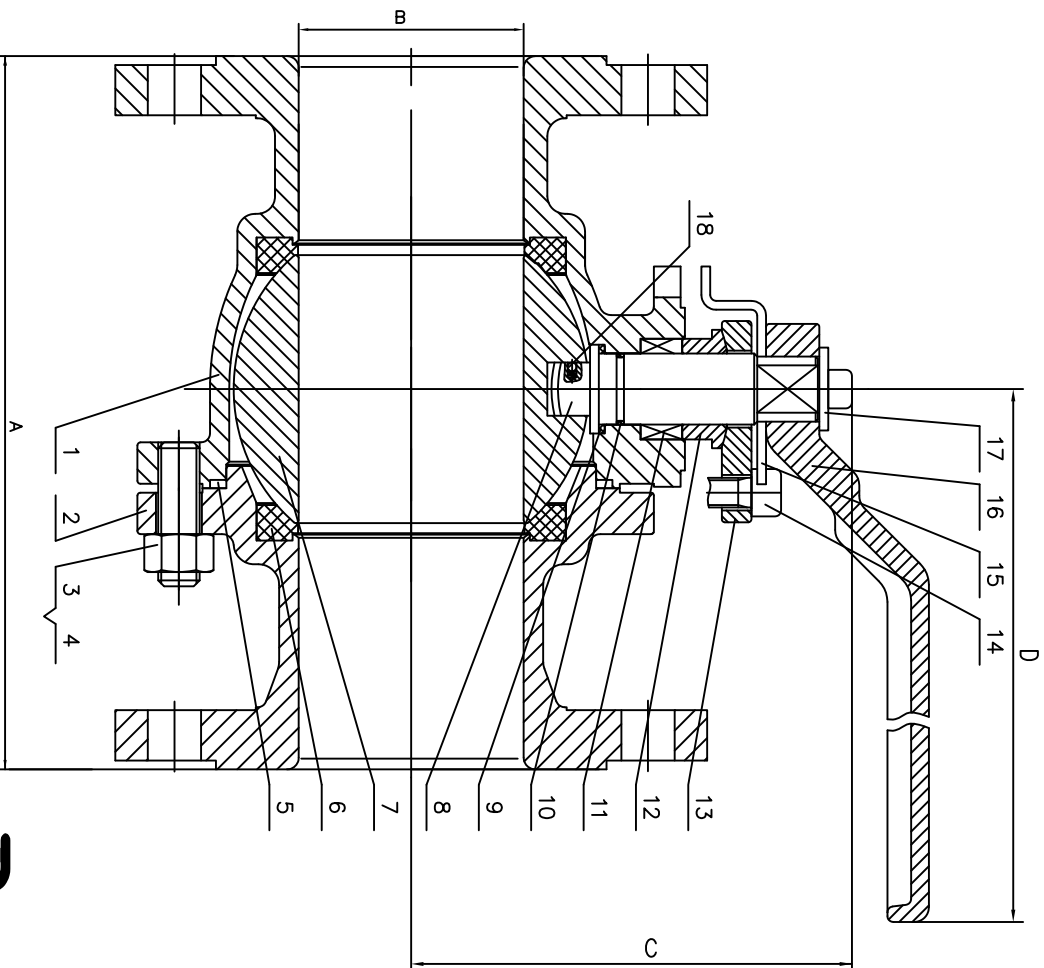

Designed to ASME B16.34/API 608
 Face to Face to ASME/ANSI B16.10
 Flange Dimensions to ASME/ANSI B16.5
 Tested to API 598
 API 607 Fire Safe
 ISO 5211 Mounting Pad

No.	Part	WCB	316SS
1	Body	WCB	CF8M
2	Bonnet	WCB	CF8M
3	Stud	A193 B7	A193 B8
4	Nut	A194 2H	A194 8
5	Gasket	316+Graphite	316+Graphite
6	Seat	RPTEF	RPTEF
7	Ball	316SS	316SS
8	Stem	316SS	316SS
9	Thrust Washer	PTFE	PTFE
10	O-Ring	VITON	VITON
11	Packing	Graphite	Graphite/PTFE
12	Packing Gland	A105	316SS
13	Gland	WCB	CF8M
14	Inner Hexagon Screw	A193 B7	A193 B8
15	Stop	SS	SS
16	Handle	WCB	CF8
17	Anti-Static	316SS	316SS

Size in	A	B	C	D	Wt lbs
1	6.5	1.0	3.3	7.5	11
1-1/2	7.5	1.5	4.1	7.5	29
2	8.5	2.0	4.3	11.0	44
2-1/2	9.5	2.5	5.3	14.2	44
3	11.0	3.0	5.7	14.2	66
4	12.0	4.0	7.3	14.2	106

Davis Valve