

# Ball Valve Full Port

**Model # 30FBA-FWFR (WCB)**

**Model # 30FBA-FFFR (316SS)**

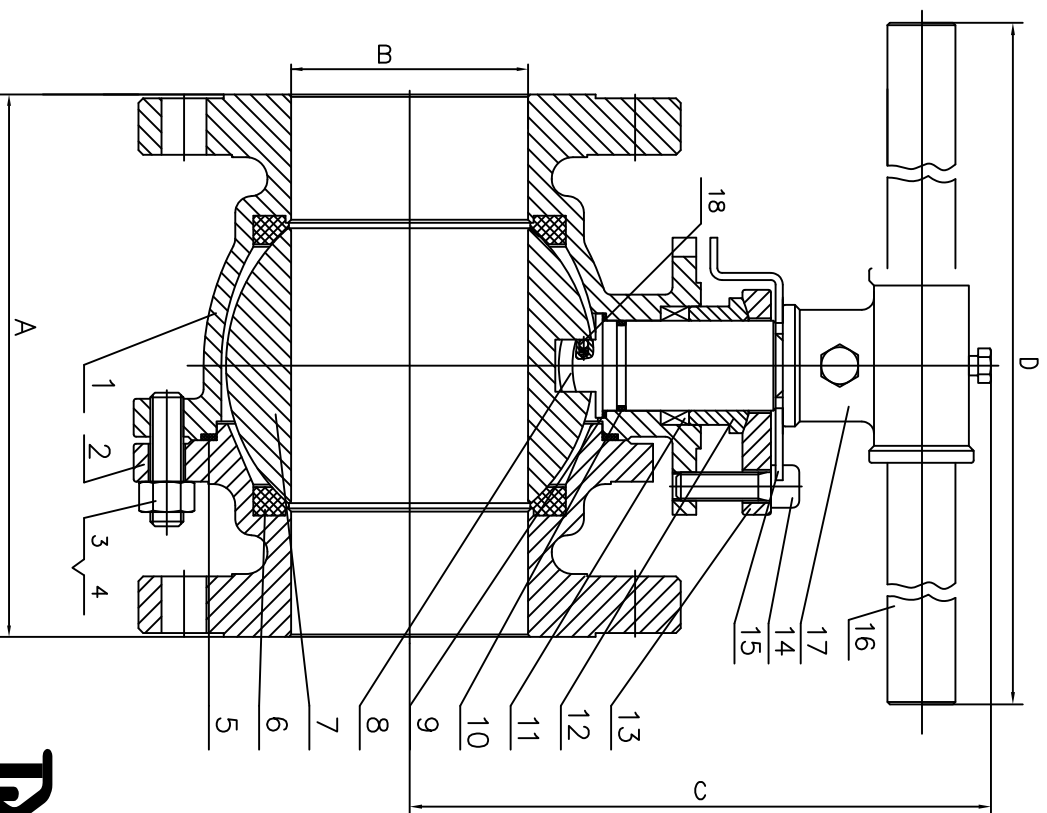

Designed to ASME B16.34/API 608  
 Face to Face to ASME/ANSI B16.10  
 Flange Dimensions to ASME/ANSI B16.5  
 Tested to API 598  
 API 607 Fire Safe  
 ISO 5211 Mounting Pad

No.	Part	WCB	316SS
1	Body	WCB	CF8M
2	Bonnet	WCB	CF8M
3	Stud	A193 B7	A193 B8
4	Nut	A194 2H	A194 8
5	Gasket	316+Graphite	316+Graphite
6	Seat	RP TFE	RP TFE
7	Ball	316SS	316SS
8	Stem	316SS	316SS
9	Thrust Washer	PTFE	PTFE
10	O-Ring	VITON	VITON
11	Packing	Graphite	Graphite/PTFE
12	Packing Gland	A105	316SS
13	Gland	WCB	CF8M
14	Inner Hexagon Screw	A193 B7	A193 B8
15	Stop	CS+Zn	SS
16	Handle	A105	A105
17	Sleeve	WCB	CF8
18	Anti-Static	316SS	316SS

Size in	A	B	C	D	Wt lbs
5	15.0	5.0	9.6	31.5	112
6	15.87	6.0	11.6	31.5	315

**Davis Valve**

Rev 2020