

# Ball Valve Full Port

**Model # 30FBA-FWFR (WCB)**

**Model # 30FBA-FFFR (316SS)**

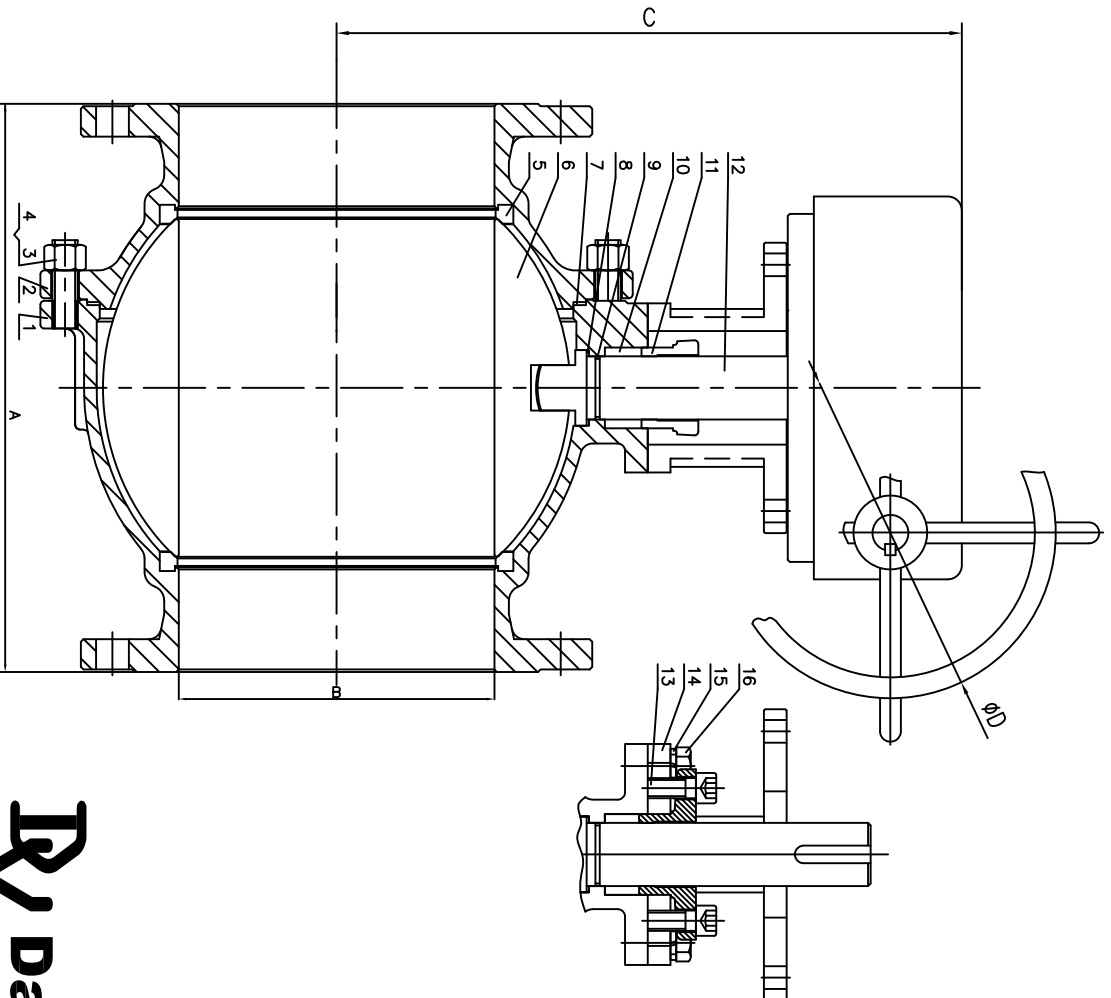

Designed to ASME B16.34/API 608  
 Face to Face to ASME/ANSI B16.10  
 Flange Dimensions to ASME/ANSI B16.5  
 Tested to API 598  
 API 607 Fire Safe  
 ISO 5211 Mounting Pad

| No. | Part                | WCB          | 316SS         |
|-----|---------------------|--------------|---------------|
| 1   | Body                | WCB          | CF8M          |
| 2   | Bonnet              | WCB          | CF8M          |
| 3   | Stud                | A193 B7      | A193 B8       |
| 4   | Nut                 | A194 2H      | A194 8        |
| 5   | Seat                | RP TFE       | RP TFE        |
| 6   | Ball                | 316SS        | 316SS         |
| 7   | Gasket              | 316+Graphite | 316+Graphite  |
| 8   | Thrust Washer       | PTFE         | PTFE          |
| 9   | O-Ring              | VITON        | VITON         |
| 10  | Packing             | Graphite     | Graphite/PTFE |
| 11  | Packing Gland       | A105         | 316SS         |
| 12  | Stem                | 316          | 316           |
| 13  | Inner Hexagon Screw | A193 B7      | A193 B8       |
| 14  | Support             | WCB+Zn       | WCB+Zn        |
| 15  | Spring Washers      | CS           | SS            |
| 16  | Screw               | B7           | B8            |

| Size in | A     | B   | C    | D    | Wt lbs |
|---------|-------|-----|------|------|--------|
| 8       | 19.75 | 8.0 | 14.6 | 18.1 | 536    |

