

Ball Valve Standard Port

Model # 30FBA-SWFR (WCB)

Model # 30FBA-SFFR (316SS)

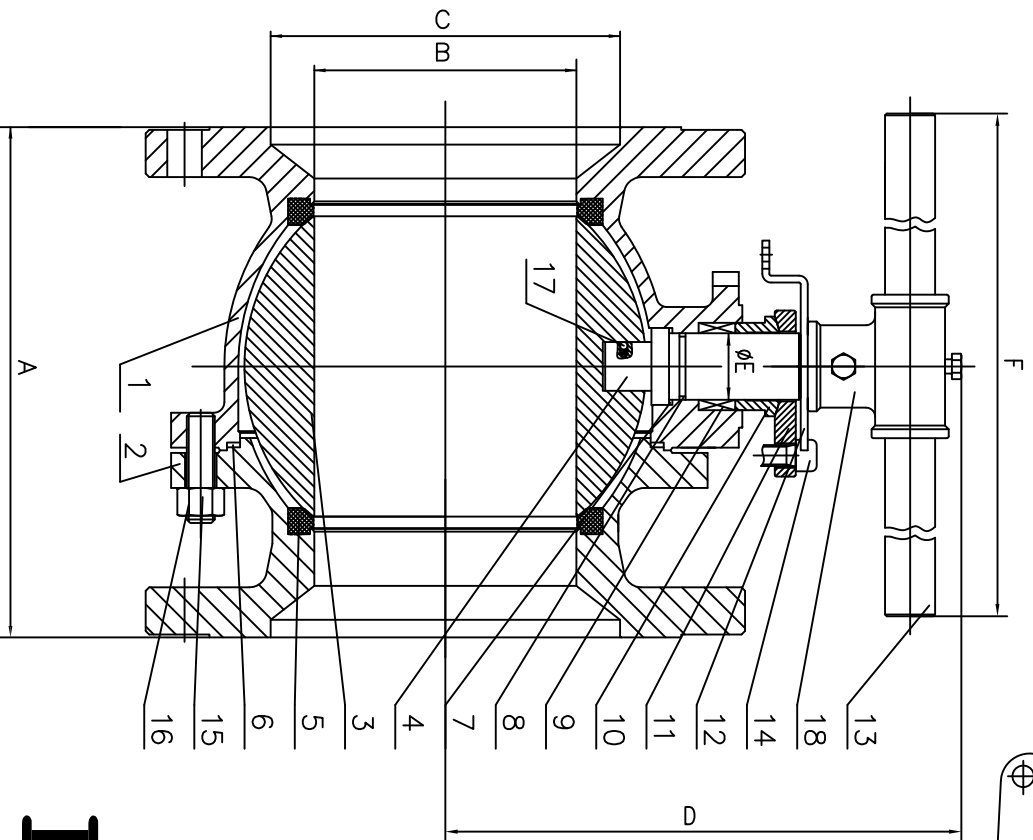
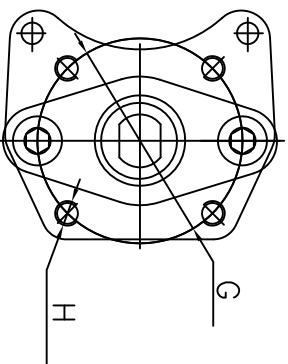

Designed to ASME B16.34/API 608
 Face to Face to ASME/ANSI B16.10
 Flange Dimensions to ASME/ANSI B16.5
 Tested to API 598
 API 607 Fire Safe
 ISO 5211 Mounting Pad

No.	Part	WCB	316SS
1	Body	WCB	CF8M
2	Bonnet	WCB	CF8M
3	Ball	316SS	316SS
4	Stem	316SS	316SS
5	Seat	RP TFE	RP TFE
6	Gasket	316+graphite	316+graphite
7	Gasket	PTFE	PTFE
8	O-Ring	VITON	VITON
9	Packing	Graphite	Graphite/PTFE
10	Packing Gland	A105	304SS
11	Gland	WCB	CF8
12	Stop	CS+Zn	304
13	T-Handle	1025+Zn	1025+Zn
14	Inner Hexagon Screw	A193 B7	A193 B8
15	Stud	A193 B7	A193 B8
16	Nut	A194 2H	A194 8
17	Anti-Static	SS	SS
18	Sleeve	WCB	WCB

Size in	A	B	C	D	E	F	G	H	Wt lbs
8	16.5	6.0	8.0	10.9	1.5	31.5	4.9	4-M12	421

Davis Valve

Rev 2020