

Forged Steel Gate Valve

Class 1500 (1/2" to 2")

FIG# 15GATF112 (F11)

Davis forged steel valves comply with the following applicable specifications: ANSI B16.34, ANSI B16.11, ANSI B1.20.1, API602, API606, MSS SP-84, BS5352: Tested to API 598

NO	PART	F11
1	BODY	A182 F11
2	SEAT	A276-410+STL
3	WEDGE	A182-F6a+STL
4	STEM	A182-F6a
5	GASKET	SPIRAL WOUND GRAPHITE + 316
6	BONNET	A182 F11
7	PACKING	FLEXIBLE GRAPHITE + SS WIRE
8	PACKING	FLEXIBLE GRAPHITE
9	PIN	A276-304
10	GLAND	A276-420
11	EYEBOLT	A193-B16
12	GLAND FLANGE	F304
13	EYEBOLT NUT	A194-8M
14	GASKET	A276-410
15	STEM NUT	A276-410
16	HANDWHEEL	A197
17	HW NUT	A194-2H
18	BOLT	A193-B16

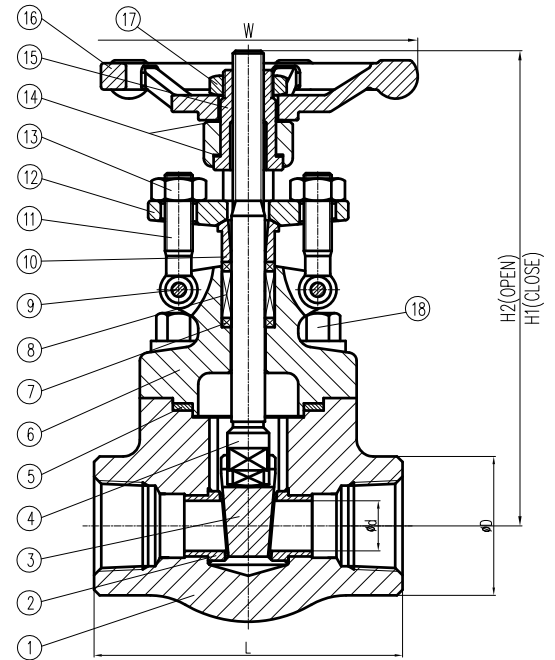

SIZE	L	H1	H2	d	D	W	WGT
1/2"	4.37	6.50	7.13	0.53	1.93	3.94	8.0
3/4"	4.37	6.50	7.13	0.53	1.93	4.92	8.2
1"	4.72	7.76	8.58	0.71	2.28	4.92	12.9
1-1/4"	4.72	8.27	9.33	0.91	2.52	6.30	22.5
1-1/2"	5.51	9.53	10.79	1.14	3.07	7.09	22.7
2"	6.30	10.51	12.13	1.42	3.46	7.87	34.5

Working Pressure: 3705 psi
Body Testing Pressure: 5560 psi
Seat Testing Pressure: 4080 psi
Air Testing Pressure: 80 psi

