

Forged Steel Gate Valve

Class 1500 (1/2" to 2")

FIG# 15GATF222WB (F22)

FIG# 15GAWF222WB (F22)

Davis forged steel valves comply with the following applicable specifications: **ANSI B16.34, ANSI B16.11, ANSI B1.20.1, API602, API606, MSS SP-84, BS5352: Tested to API 598**

NO	PART	F22
1	BODY	A182 F22
2	SEAT	A276-410+STL
3	WEDGE	A182-F6a+STL
4	STEM	A182-F6a
5	BONNET	A182 F22
6	PACKING	FLEXIBLE GRAPHITE + SS WIRE
7	PACKING	FLEXIBLE GRAPHITE
8	PIN	A276-304
9	GLAND	A276-420
10	EYEBOLT	A193-B16
11	GLAND FLANGE	A182-F304
12	EYEBOLT NUT	A194-8M
13	STEM NUT	A276-410
14	GASKET	A276-410
15	HANDWHEEL	A197
16	HW NUT	A194-2H

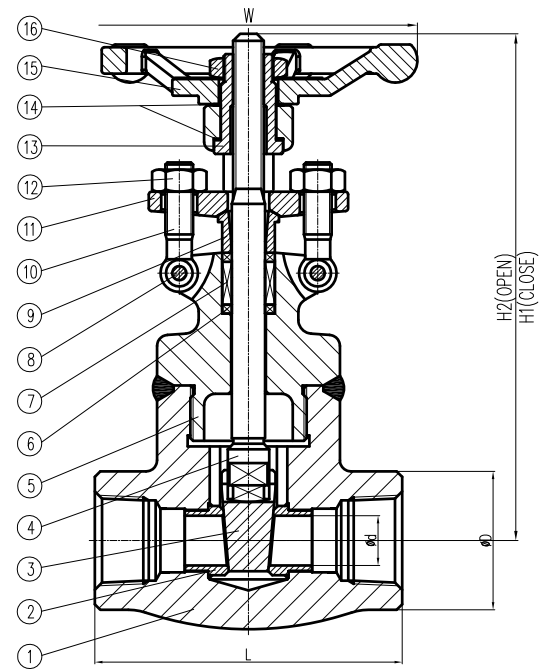

SIZE	L	H1	H2	d	D	W	WGT
1/2"	4.37	6.50	7.13	0.53	1.93	3.94	8.0
3/4"	4.37	6.50	7.13	0.53	1.93	4.92	8.2
1"	4.72	7.76	8.58	0.71	2.28	4.92	12.9
1-1/4"	4.72	8.27	9.33	0.91	2.52	6.30	22.5
1-1/2"	5.51	9.53	10.79	1.14	3.07	7.09	22.7
2"	6.30	10.51	12.13	1.42	3.46	7.87	34.5

Working Pressure: 3705 psi
Body Testing Pressure: 5560 psi
Seat Testing Pressure: 4080 psi
Air Testing Pressure: 80 psi

