

Forged Steel WB Gate Valve

Model# 25GAWFS2WB (A105)

Model# 25GAWF222WB (F22)

2500#

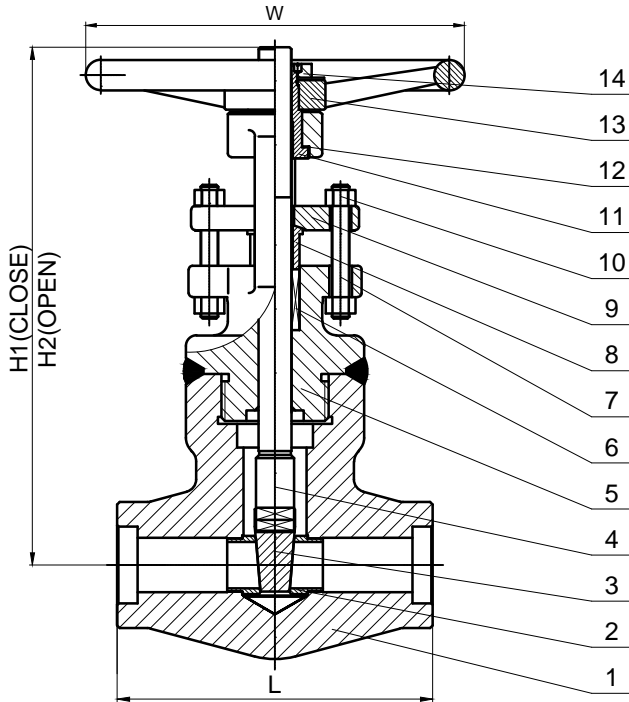

Davis forged steel valves comply with the following applicable specifications: API 602, ASME B16.34
Tested to: API 598

No	Part Name	Material A105	Material F22
1	Body	A105	F22
2	Seat	Integral Hard Faced	Integral Hard Faced
3	Wedge	A182-F6a+STL	A182-F6a+STL
4	Stem	A182-F6a	A182-F6a
5	Bonnet	A105	F22
6	Packing	Flexible Graphite+SS Wire	Flexible Graphite+SS Wire
7	Stud	A193-B7	A193-B16
8	Gland	A276-420	A276-420
9	Gland Flange	A105	F304
10	Nut	A194-2H	A194-8M
11	Stem Nut	A276-410	A276-410
12	Gasket	A276-410	A276-410
13	Handwheel	A197	A197
14	Handwheel Nut	A194-2H	A194-2H

Size in	L	H1	H2	W	WGT lbs
1/2	5.9	9.25	10.0	7.9	12.3
3/4	5.9	9.25	10.0	7.9	19.4
1	6.7	10.1	11.1	7.9	26.9
1-1/4	7.9	12.2	13.3	11.8	39.7
1-1/2	7.9	12.2	13.5	11.8	41.9
2	9.1	14.1	16.7	11.8	62.8

 Davis Valve