

Forged Steel Flanged Gate Valve

Model# 15GAFFS1
1500#

Davis forged steel valves comply with the following applicable specifications: API 602, ASME B16.34
Tested to: API 598

No	Part Name	Material
1	Body	A105
2	Seat	A276-410+STL
3	Wedge	A276-420
4	Stem	A182-F6a
5	Bonnet Gasket	Spiral Wound Graphite+304
6	Bonnet	A105
7	Packing	Flexible Graphite+SS Wire
8	Packing	Flexible Graphite
9	Pin	A276-410
10	Gland	A276-420
11	Eyebolt	A193-B7
12	Gland Flange	A105
13	Eyebolt Nut	A194-2H
14	Washer	A276-410
15	Stem Nut	A276-410
16	Handwheel	A197
17	Handwheel Nut	A194-2H
18	Bolt	A193-B7
19	Nut	A194-2H

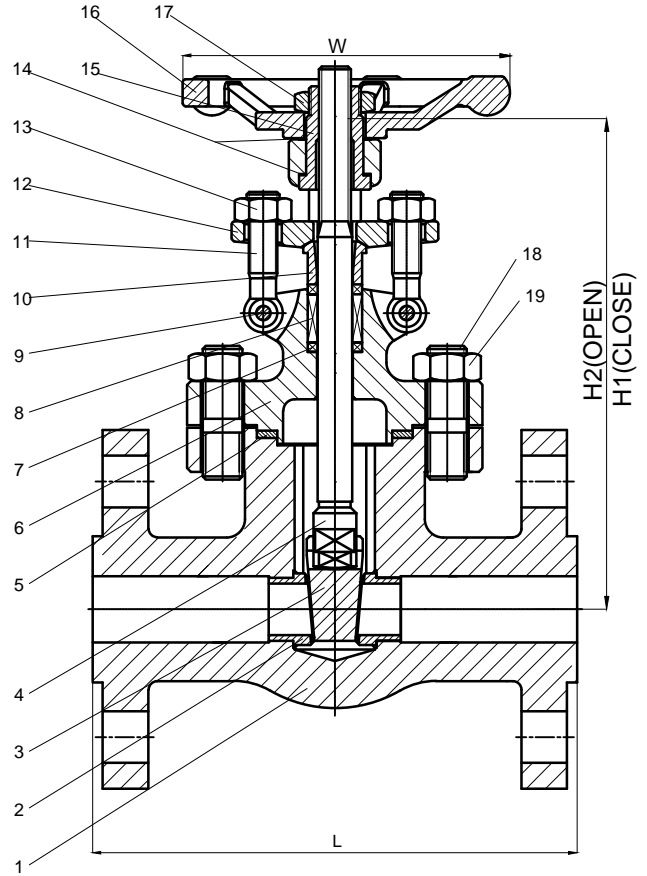

Size in	L	H1	H2	W	WGT lbs
1/2	8.5	6.5	7.13	5.0	15
3/4	9.0	6.5	7.13	5.0	21
1	10.0	7.75	8.6	6.3	32
1-1/2	12.0	9.5	10.8	7.1	63

