

Forged Steel Swing Check

**Class 150-600 (1/2" to 2")
Flanged Ends**

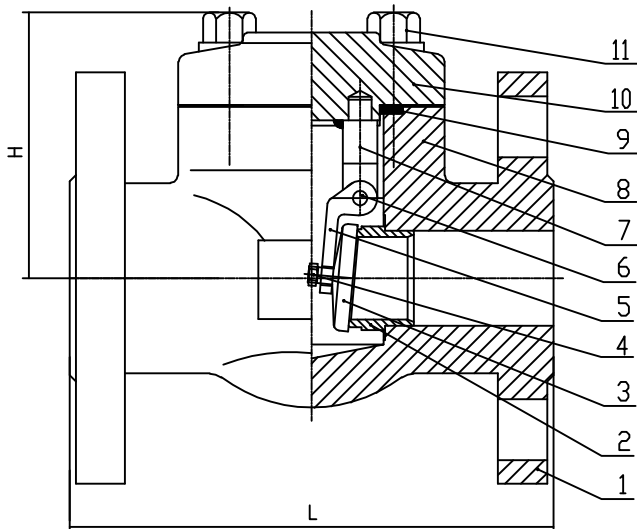

Davis forged steel valves comply with the following applicable specifications: API 602, API B16.5, MSS SP-25: Tested to API 598

NO.	PART NAME	MATERIAL
1	FLANGE	A105
2	SEAT	A276-410 Hard Faced
3	DISC	A276-420
4	NUT	SS 304
5	ROCKER	F316
6	PIN	SS 304
7	PIN	F13CR
8	BODY	A105
9	GASKET	Spiral Wound 304+Graphite
10	BONNET	A105
11	BONNET BOLT	A193-B7

Class 150 - Model # 1SCFFS1

Size	1/2"	3/4"	1"	1 1/4"	1 1/2"	2"
L	4.25	4.6	5	5.5	6.5	8
H	2	2.4	2.8	3.23	3.23	4.17
W/lbs	5.64	6.48	10.66	14.21	15.67	23.41

Class 300 - Model # 3SCFFS1

Size	1/2"	3/4"	1"	1 1/4"	1 1/2"	2"
L	6	7	8.5	8.5	9.5	10.5
H	2	2.4	2.8	3.23	3.23	4.17
W/lbs	5.94	7.7	12.32	16.5	17.62	26.62

Class 600 - Model # 6SCFFS1

Size	1/2"	3/4"	1"	1 1/4"	1 1/2"	2"
L	6.5	7.5	8.5	9	9.5	11.5
H	2	2.4	2.8	3.23	3.23	4.17
W/lbs	6.16	8.36	13.64	18.92	21.12	32.34

