

Forged Stainless Lift Check

Class 800 (1/2" to 2")

Class 1500 (1/2" to 2")

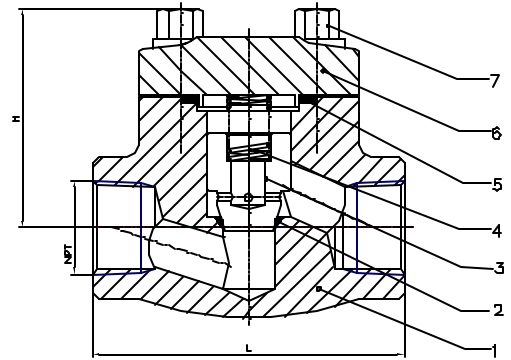

NO.	PART NAME	MATERIAL
1	BODY	F316L
2	SEAT	A276-316 Hard Faced
3	DISC	A276-316
4	SPRING	316SS
5	GASKET	Spiral Wound 316+Graphite
6	BONNET	316L
7	BOLT	A193-B8

Davis forged stainless valves comply with the following applicable specifications: ANSI B16.34, ANSI B16.11, ANSI B1.20.1, API602, API606, MSS SP-84, BS5352: Tested to API 598

Class 800

8LCT3M4 - Threaded
8LCW3M4 - Socket Weld

Size	1/2"	3/4"	1"	1 1/4"	1 1/2"	2"
L	3.11	3.62	4.37	4.72	6	6.77
H	2.44	2.48	3.1	3.23	4	4.72
Wt/lbs	3.84	4.06	6.55	9.03	13.77	22.8

Working Pressure: 1600 psi
Body Testing Pressure: 2400 psi
Seat Testing Pressure: 1760 psi
Air Testing Pressure: 80 psi

Class 1500

15LCT3M4 - Threaded
15LCW3M4 - Socket Weld

Size	1/2"	3/4"	1"	1 1/4"	1 1/2"	2"
L	4.37	4.37	4.73	6	6.77	8.66
H	3.86	3.86	4	4.72	5.5	6.22
Wt/lbs	4.06	6.55	9.03	13.77	22.8	31.6

Working Pressure: 3000 psi
Body Testing Pressure: 4500 psi
Seat Testing Pressure: 3300 psi
Air Testing Pressure: 80 psi

