

# High Performance Wafer Butterfly

With Lever Op (2"-4")

Model # 30WW-L (WCB)

Model # 30WF-L (316SS)

Technical Requirements	
1. All Dimensions in inches	
2. Valve Design	: API609/ASME B16.34
3. Flange Dimension	: ASME B16.5
4. Face to Face Dimension	: API609
5. Testing Standard	: API598

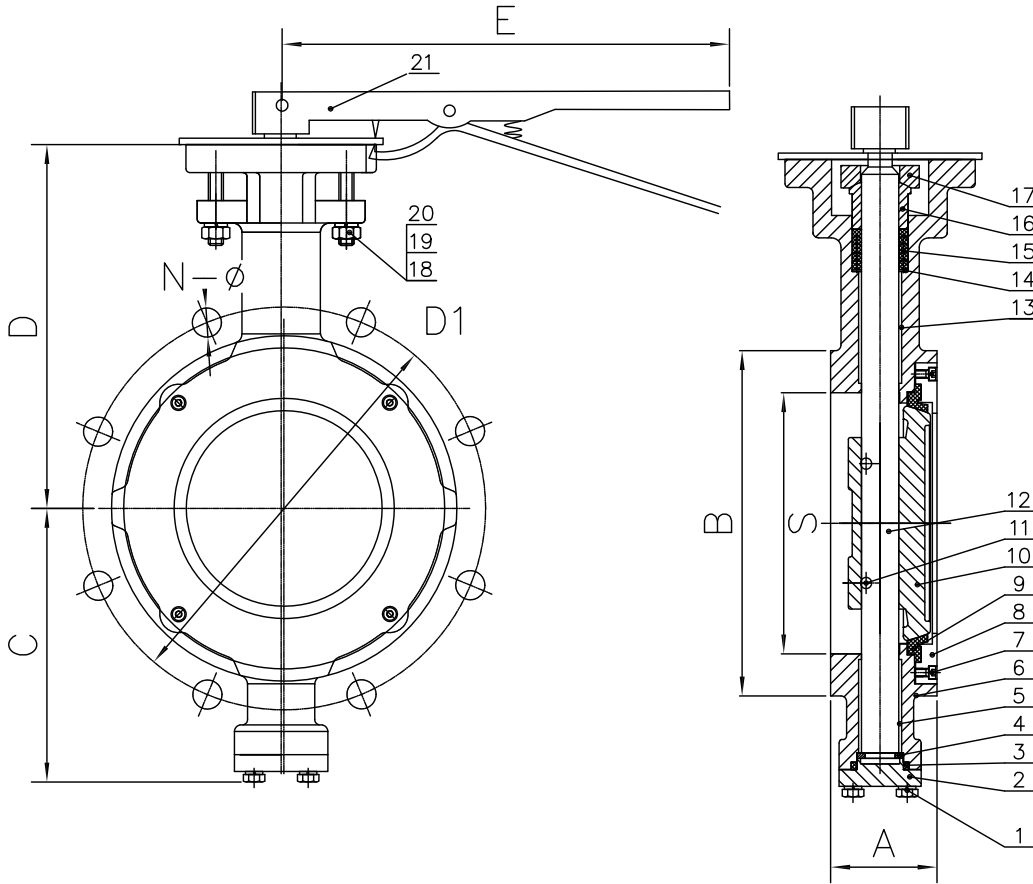

No	Part	Material WCB	Material 316SS
1	Bolt	A193 B7	A193 B8M
2	Bottom Cover	A105	A182 F316
3	Seal Gasket	RPTFE	RPTFE
4	Bisect Ring	A276 420	A276 316
5	Bushing	PTFE + SS	PTFE + SS
6	Body	A216 WCB	A351 CF8M
7	Bolt	A193 B8M	A193 B8M
8	Clamp	A182 F316	A182 F316
9	Seat	RPTFE	RPTFE
10	Disc	A351 CF8M	A351 CF8M
11	Pin	17-4PH	17-4PH
12	Stem	17-4PH	17-4PH
13	Bushing	PTFE + SS	PTFE + SS
14	Packing Seat	304SS	316SS
15	Packing	RPTFE	RPTFE
16	Packing Ring	A276 420	A182 F316
17	Packing Gland	A216 WCB	A351 CF8M
18	Bolt	A193 B7	A193 B8M
19	Nut	A194 2H	A194 8M
20	Spring Gasket	ASTM A29 1566	316SS
21	Lever	SS	SS

S in	A	B	C	D	E	D1	N-ø	Wgt lbs
2	1.73	4.02	4.13	4.96	9.65	5.00	8-ø0.75	7
2.5	1.89	4.49	4.45	5.91	9.65	5.87	8-ø0.87	11
3	1.93	5.12	4.84	6.30	9.65	6.63	8-ø0.87	15
4	2.13	6.19	5.75	6.93	10.83	7.87	8-ø0.87	20