

CAST STEEL FLANGED LUBRICATED PLUG VALVE 6"-12"

Pressure Balanced Lubricated Plug Valve

150#

MODEL# 15FPLW-PB

Technical Requirements:

Design & Manufacture	API 6D
Material Press-Temp Rating	ASME/ANSI 16.34
End to End Dimension	API 6D/ASME B16.10
Flange Dimension	ASME/ANSI B16.5
Test & Inspect	API 6D
Fire Safe Design	API 6FA
Special Requirements	NACE MR 01 75

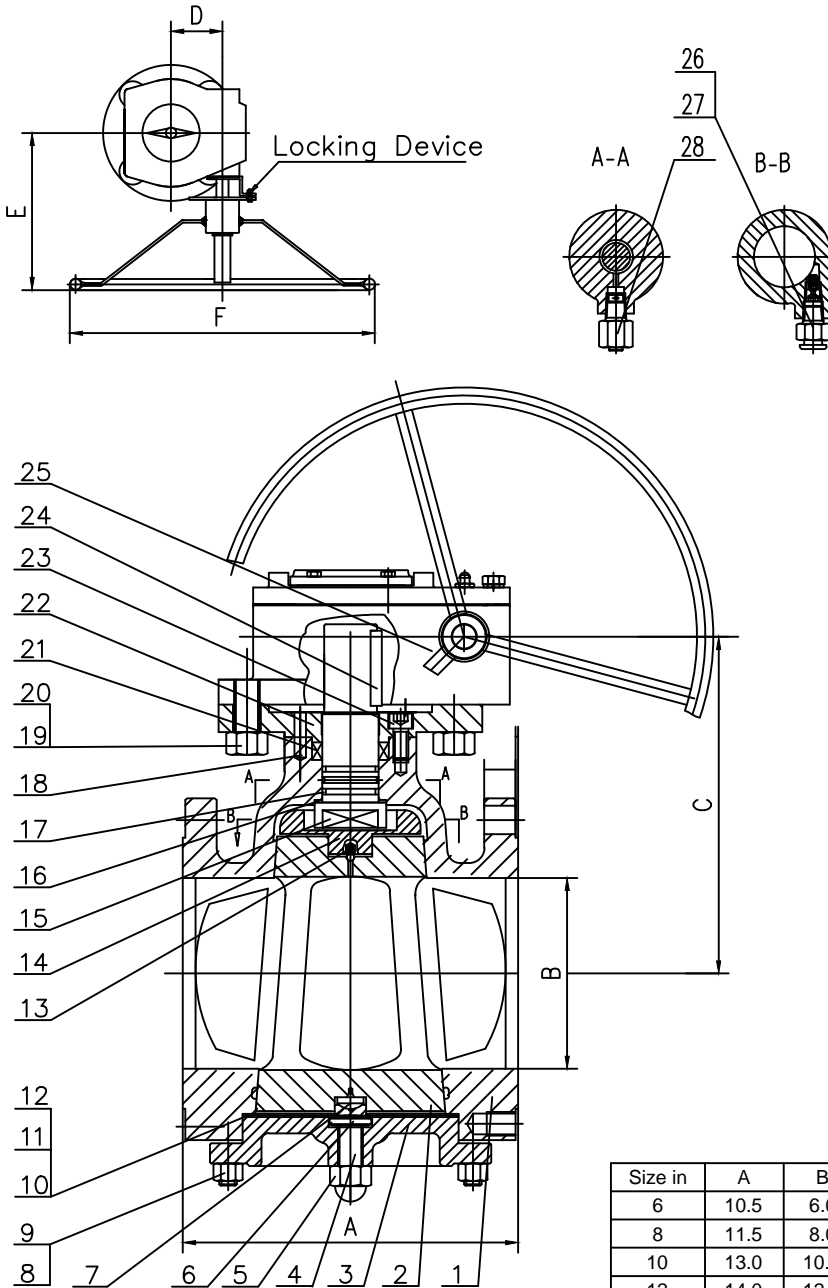

No.	Part	Material
1	Body	A216 WCC
2	Plug	A216 WCC+ENP
3	Lower Cover	A216 WCC
4	Adjustable Bolt	A193 B7M
5	Nut	A29 1025
6	Adjustable Block	A29 1035
7	Bearing	A276 410+SH
8	Bolt	A193 B7M
9	Nut	A194 2HM
10	Gasket	Flexible Graphite+304
11	Steel Washer	304SS
12	Steel Plate	A36
13	Check Valve	304SS
14	Hub	A216 WCC
15	Stem	AISI 410
16	Thrust Bearing	PTFE
17	O-Ring	VITON
18	Pin	AISI 1045
19	Bolt	ISO CL 6.8
20	Nut	ISO CL6
21	Braid Packing	Flexible Graphite
22	Gland	A105
23	Bolt	ISO CL 8.8
24	Key	AISI 1045
25	Gear	CI/CS
26	Check Valves	A29 1035
27	Grease Fitting	A29 1035
28	Packing Injector	A29 1035

Size in	A	B	C	D	E	F	Wt lbs
6	10.5	6.0	10.6	3.1	9.8	13.8	207
8	11.5	8.0	11.5	3.5	11.8	18.1	342
10	13.0	10.0	13.6	5.0	19.7	23.6	430
12	14.0	12.0	14.9	5.0	19.7	23.6	706

