

# Stainless Steel Gate Valve

Model #10

Class 600 (2" to 12")

Designed to ANSI B16.34,  
API 603, tested to API 598.  
Face to face ANSI B16.10,  
Flanges to ANSI B16.5

Full port  
Precision machined flexible wedge gate and seat for tight shutoff  
Heavy duty cast construction  
Body-guided wedge insures alignment, low closing torques and reduced noise and vibration  
Integral backseat  
Outside screw and yoke, non-rising handwheel, rising stem  
Locking handwheel nut  
Rugged carbon steel handwheel  
Available in a wide range of alloys

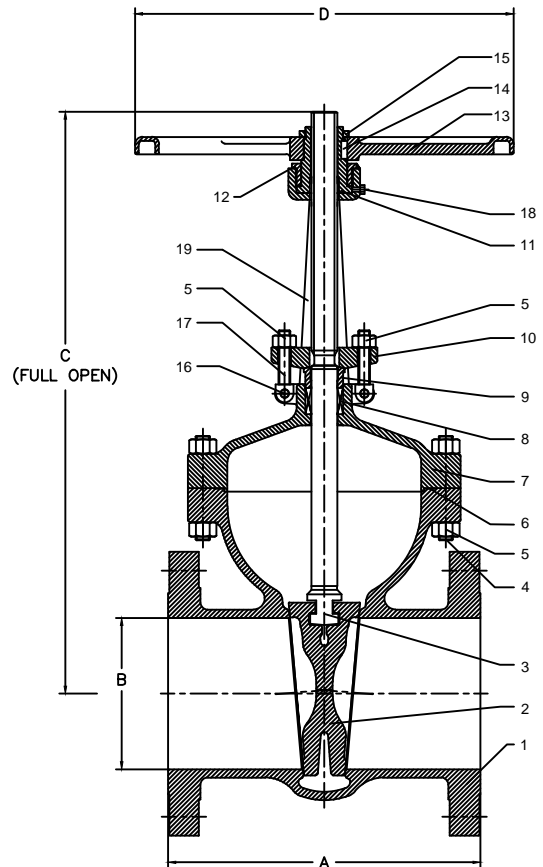

NO.	PART NAME	CF8M	A 351-CN7M
1	BODY	CF8M	A 351-CN7M
2	WEDGE	CF8M	A 351-CN7M
3	STEM	316	A 351-CN7M
4	STUD	A 193-B8	A 193-B8M
5	HEX NUT	A 194-8	A 194-8M
6	GASKET	PTFE	PTFE
7	BONNET	CF8M	A 351-CN7M
8	GLAND PACKING	BRAIDED PTFE	BRAIDED PTFE
9	GLAND BUSH	316	A 351-CN7M
10	GLAND FLANGE	316	A 351-CN7M
11	STEM NUT	AL BRZ (B 148-Gr D)	AL BRZ (B 148-Gr D)
12	BONNET BUSH	A276-304/A 351-CF8	A276-304/A 351-CF8
13	HAND WHEEL	A 216-WCB/DUCTILE IRON	A 216-WCB/DUCTILE IRON
14	PARALLEL KEY	C 40	C 40
15	HAND WHEEL NUT	C 45 (BLACKODISED)	C 45 (BLACKODISED)
16	GROOVED PIN	A 276-316	A 276-316
17	GLAND BOLT	A 182-F304	A 182-F304
18	GREASE NIPPLE	A 276-304	A 276-304
19	YOKE	A 351-CF8M	A 351-CN7M

SIZE	INCH	2	2-1/2	3	4	6	8	10	12
	MM	50	65	80	100	150	200	250	300
A *	INCH	11.5	13.0	14.0	17.0	22.0	26.0	31.0	33.0
	MM	292.1	330.2	355.6	431.8	558.8	660.4	787.4	838.2
B	INCH	2	2.5	3	4	6	7.87	9.75	11.75
	MM	51	64	76	102	152	200	248	299
C	INCH	14.96	18.0	20.7	26.5	34.0	41.1	47.2	61.9
	MM	380.0	457.0	515.0	673	865	1045	1200	1573
D	INCH	10	14	14	18	20	20	25	25
	MM	254	358	358	457	508	508	635	635
Weight	LBS	87	120	127	257	492	798	1408	1975
	KGS	40	55	58	117	223	362	639	896

\* BWE dimensions are the same as flanged

