

Stainless Steel Globe Valve

Model #20

Class 300 (1" to 10")

Designed to ANSI B16.34,
API 603, tested to API 598.
Face to face ANSI B16.10,
Flanges to ANSI B16.5

Precision machined globe and seat for tight shutoff
Heavy duty cast construction
Body-guided disc insures alignment, low noise and
low vibration
Integral backseat
Locking handwheel nut
Rugged carbon steel handwheel
Available in a wide range of alloys

NO.	PART NAME	A 351-CF8M	A 351-CN7M
1	BODY	A 351-CF8M	A 351-CN7M
2	SEAT	A 351-CF8M	A 351-CN7M
3	DISC	A 351-CF8M	A 351-CN7M
4	THRUST PAD	A 276-316	A 351-CN7M
5	BALL/STEM COLLAR	A 276-316	A 351-CN7M
6	SOCKET SET SCREW/RETAINER	A 276-316	A 351-CN7M
7	STEM	A 276-316	A 351-CN7M
8	SW GASKET	PTFE	PTFE
9	BONNET	A 351-CF8M	A 351-CN7M
10	STUD	A 193-B8	A 193-B8M
11	HEAVY HEX NUT	A 194-8	A 194-8M
12	GLAND PACKING	BRIADED PTFE	BRIADED PTFE
13	GLAND BUSH	A 276-316	A 351-CN7M
14	GLAND FLANGE	A 351-CF8M	A 351-CN7M
15	STEM NUT	AL BRONZE (B 148-Gr D)	AL BRONZE (B 148-Gr D)
16	HAND WHEEL	A 216-WCB/DUCTILE IRON	A 216-WCB/DUCTILE IRON
17	WASHER	A 276-304	A 276-304
18	NYLOCK NUT	A 276-304	A 276-304
19	GLAND BOLT	A 182-F304	A 182-F316
20	GROOVE PIN	A 276-304	A 276-304

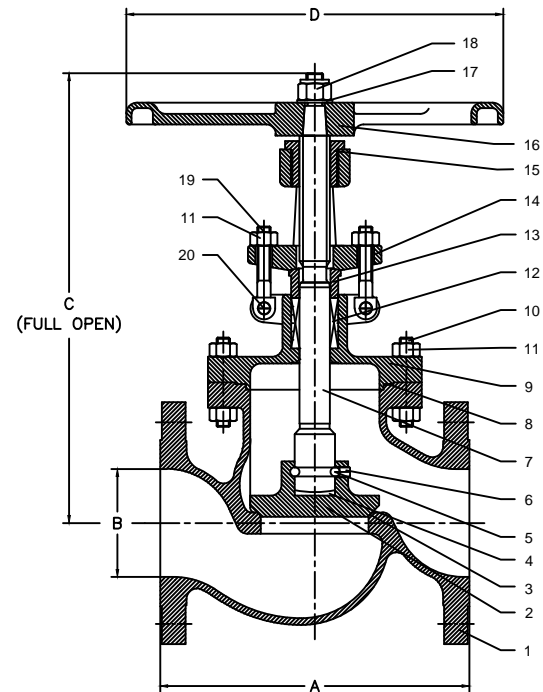

SIZE	INCH	1	1-1/2	2	3	4	6	8	10
	MM	25	40	50	80	100	150	200	250
A	INCH	8.0	9.0	10.5	12.5	14.0	17.5	22.0	24.5
	MM	203.2	228.6	266.7	317.5	355.6	444.5	558.8	622.3
B	INCH	1	1.5	2	3	4	6	8	10
	MM	25	38	51	76	102	152	203	254
C	INCH	9.75	11.0	12.6	16.35	20.15	24.4	28.20	35.0
	MM	247.7	279.4	321	415.3	512	620	716	889
D	INCH	5	8	8	10	14	18	20	25
	MM	127	203	203	254	356	457	508	635
Weight	LBS	21	38	49	97	147	297	508	858
	KGS	10	17	22	44	67	135	230	389

