

# Stainless Steel Swing Check

Model # 30F-150

Class 150 (1/2" to 12")

Unique full port  
 Heavy duty cast construction  
 Bolted cover  
 Precision machined self-aligning disc ensures perfect  
 seating of disc against body seat  
 Available in a wide range of alloys

Designed and tested to  
 ANSI B16.34, API 598,  
 API 6D face to face ANSI B16.10  
 Flanges to ANSI B16.5

NO.	PART NAME	A 351-CF8M	A 351-CN7M
1	BODY	A 351-CF8M	A 351-CN7M
2	SEAT	A 351-CF8M	A 351-CN7M
3	DISC	A 351-CF8M	A 351-CN7M
4	DISC CARRIER	A 351-CF8M	A 351-CN7M
5	COTTER PIN	A 276-316	A 351-CN7M
6	PIN	A 276-316	A 351-CN7M
7	HEX NUT	A 194-8M	A 351-CN7M
8	PLAIN WASHER	A 276-316	A 351-CN7M
9	STUD	A 193-B8	A 193-B8M
10	HEX NUT	A 194-8	A 194-8M
11	GASKET	PTFE	PTFE
12	COVER	A 351-CF8M	A 351-CN7M
13	NPT PIN PLUG	SS 316	A 351-CN7M

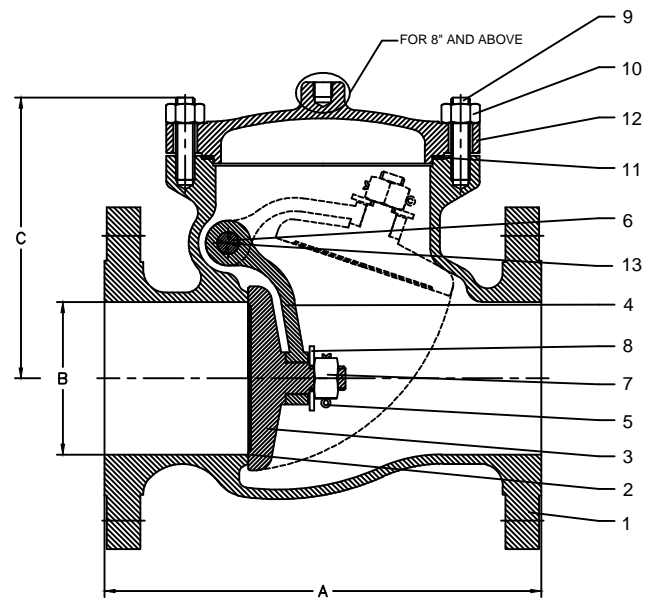

SIZE	INCH	1/2	3/4	1	1-1/2	2	2-1/2	3	4	5	6	8	10	12
	MM	15	20	25	40	50	65	80	100	125	150	200	250	300
A	INCH	4.25	4.62	5.00	6.50	8.00	8.50	9.50	11.50	13.00	14.00	19.50	24.50	27.5
	MM	108.0	117.4	127.0	165.1	203.2	215.9	241.3	292.1	330.2	355.6	495.3	622.3	698.5
A (BWE)	INCH					8.00	8.50	9.50	11.50	13.00	14.00	19.50	24.50	27.5
	MM					203.2	215.9	241.3	292.1	330.2	355.6	495.3	622.3	698.5
B	INCH	1/2	3/4	1	1.5	2	2.5	3	4	5	6	8	10	12
	MM	15	20	25	38	51	64	76	102	127	152	203	254	305
C	INCH	3.15	3.15	3.15	3.46	5.07	5.6	6.3	7.4	8.0	8.86	10.73	12.6	15.9
	MM	80	80	80	88	129	142	160	188	203	225	272.5	320	403
Weight	LBS	7	8	11	15	23	33	48	74	108	134	233	343	503
	KGS	3	4	5	7	10	15	22	34	49	61	106	156	228

