

Stainless Steel Swing Check

Model #30
Class 900 (2" to 8")

Designed and tested to
ANSI B16.34, API 598,
API 6D face to face ANSI B16.10
Flanges to ANSI B16.5

Unique full port
Heavy duty cast construction
Bolted cover
Precision machined self-aligning disc ensures perfect
seating of disc against body seat
Available in a wide range of alloys

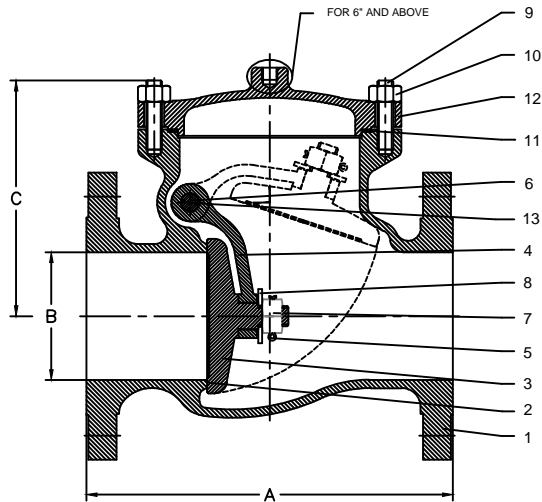

NO.	PART NAME	A 351-CF8M	A 351-CN7M
1	BODY	A 351-CF8M	A 351-CN7M
2	SEAT	A 351-CF8M	A 351-CN7M
3	DISC	A 351-CF8M	A 351-CN7M
4	DISC CARRIER	A 351-CF8M	A 351-CN7M
5	COTTER PIN	A 276-316	A 351-CN7M
6	PIN	A 276-316	A 351-CN7M
7	HEX NUT	A 194-8M	A 351-CN7M
8	PLAIN WASHER	A 276-316	A 351-CN7M
9	STUD	A 193-B8	A 193-B8M
10	HEX NUT	A 194-8	A 194-8M
11	GASKET	PTFE	PTFE
12	COVER	A 351-CF8M	A 351-CN7M
13	NPT PIN PLUG	SS 316	A 351-CN7M

SIZE	INCH	2	3	4	6	8
	MM	50	80	100	150	200
A	INCH	14.5	15.0	18.0	24.0	29.0
	MM	368.3	381.0	457.2	609.6	736.6
B	INCH	1.87	2.87	3.87	5.75	7.5
	MM	47.49	72.89	98.29	146.1	190.5
C	INCH	6.9	7.4	8.5	11.0	11.4
	MM	176.3	189.0	215.9	279.4	290.4

 Davis Valve