

# Wafer Check Valve 2500#

**Model 25061 - WCB Body / 316 Disc - Metal Seat**

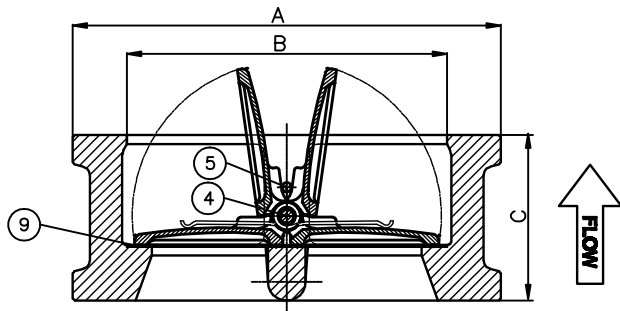
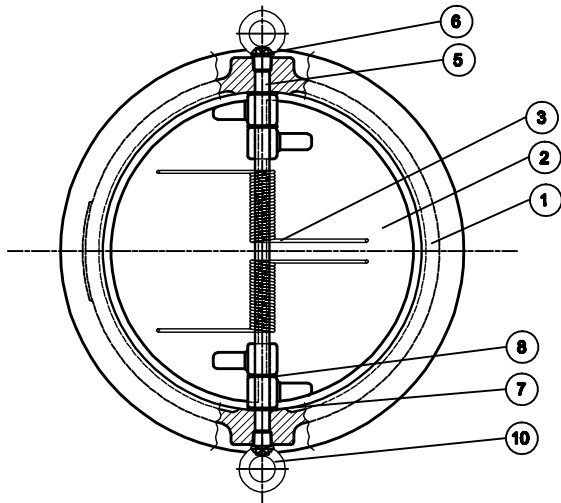

General Valve Design: API 594  
 Working Pressure: ASME B16.34  
 Face to Face Dimension: API 594  
 Materials: ASTM  
 Valve Testing: API 598

PART NO.	PART NAME	MATERIAL	Q'TY	REMARK
1	BODY	A216 -WCB	1	
2	PLATE	CF8M	2	
3	SPRING	INCONEL	1	2 ~ 5"
			2	6"~20"
			4	24"~36"
4	HINGE PIN	316 SS	1	
5	STOP PIN	316 SS	1	
6	RETAINER	316 SS	4	
7	BODY BEARING	316 SS	2	
8	PLATE BEARING	316 SS	2	
9	SEAT	METAL	1	
10	EYE BOLT	A105	1	6"~20"
			2	24"~36"

SIZE	INCH	1½	2	2½	3	4	5	6	8	10	12	14	16	18	20	24	30	36
	MM	38	50	65	80	100	127	150	200	250	300	350	400	450	500	600	762	915
A	INCH	-	5.75	6.61	7.75	9.25	-	12.5	15.25	18.75	21.61	0	-	-	-	-	-	-
	MM	-	146	168	197	235	-	318	387	476	549	-	-	-	-	-	-	-
B	INCH	-	2.37	2.87	3.5	4.5	-	6.62	8.62	10.75	12.75	-	-	-	-	-	-	-
	MM	-	60	73	89	114	-	168	219	274	324	-	-	-	-	-	-	-
C	INCH	-	2.75	3.25	3.39	4.13	-	6.25	8.11	10.0	12.0	-	-	-	-	-	-	-
	MM	-	70	83	86	105	-	159	206	254	305	-	-	-	-	-	-	-
WGT	LBS	-	14	22	31	55	-	148	286	500	875	-	-	-	-	-	-	-
	KGS	-	6.4	10	14	25	-	67	130	227	397	-	-	-	-	-	-	-

