

Wafer Check Valve 300#

Model 3061-NACE - WCB Body / 316 Disc - 316 Metal Seat

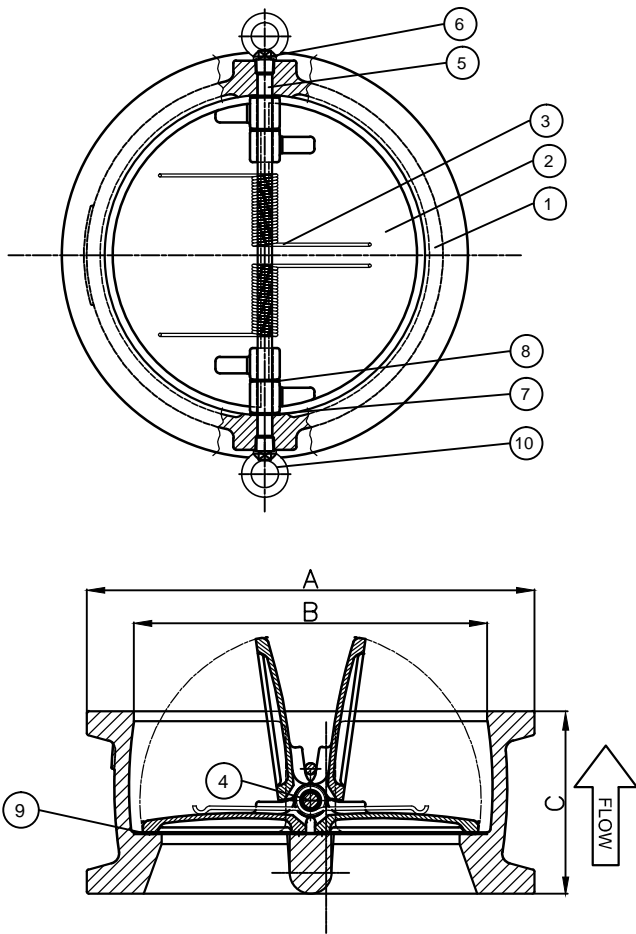

General Valve Design: API 594
 Working Pressure: ASME B16.34
 Face to Face Dimension: API 594
 Materials: ASTM
 Valve Testing: API 598
 NACE MRO-175

PART NO.	PART NAME	MATERIAL	Q'TY	REMARK
1	BODY	A216 -WCB	1	
2	PLATE	CF8M	2	
3	SPRING	INCONEL	1	1½ ~ 5"
			2	6"~20"
			4	24"~36"
4	HINGE PIN	316 SS	1	
5	STOP PIN	316 SS	1	
6	RETAINER	316 SS	4	
7	BODY BEARING	316 SS	2	
8	PLATE BEARING	316 SS	2	
9	SEAT	316 SS	1	
10	EYE BOLT	A105	1	6"~20"
			2	24"~36"

SIZE	INCH	1-1/2	2	2-1/2	3	4	5	6	8	10	12	14	16	18	20	24	30	36
	MM	38	50	65	80	100	127	150	200	250	300	350	400	450	500	600	762	915
A	INCH	-	4.37	5.12	5.87	7.13	8.5	9.88	12.13	14.25	16.61	19.13	21.26	23.5	25.75	30.5	37.5	-
	MM	-	111	130	149	181	216	251	308	362	422	486	540	597	654	775	953	-
B	INCH	-	2.37	2.87	3.5	4.5	5.56	6.62	8.62	10.75	12.75	14	16	18	20	24	30	-
	MM	-	60	73	89	114	141	168	219	274	324	356	406	457	508	610	762	-
C	INCH	-	2.37	2.63	2.88	2.88	3.38	3.88	5.0	5.75	7.13	8.75	9.13	10.38	11.5	93.0	15.69	-
	MM	-	60	67	73	73	86	98	127	146	181	222	232	264	12.5	318	398	-
WGT	LBS	-	6	10	13	15	35	38	65	104	152	325	355	520	700	1050	1650	-
	KGS	-	2.7	5	6	7	16	17	29	47	69	147	161	236	318	476	748	-

