

Wafer Check Valve 600#

Model 6061-NACE - WCB Body / 316 Disc - 316 Metal Seat

General Valve Design: API 594
 Working Pressure: ASME B16.34
 Face to Face Dimension: API 594
 Materials: ASTM
 Valve Testing: API 598
 NACE MRO-175

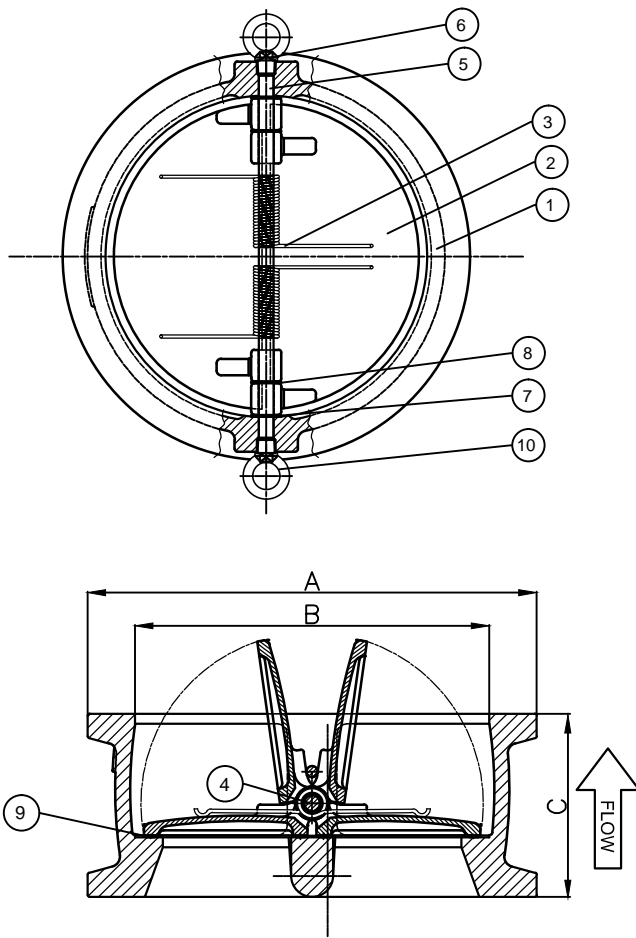

PART NO.	PART NAME	MATERIAL	Q'TY	REMARK
1	BODY	A216 -WCB	1	
2	PLATE	CF8M	2	
3	SPRING	INCONEL	1	1½ ~ 5"
			2	6"~20"
			4	24"~36"
4	HINGE PIN	316 SS	1	
5	STOP PIN	316 SS	1	
6	RETAINER	316 SS	4	
7	BODY BEARING	316 SS	2	
8	PLATE BEARING	316 SS	2	
9	SEAT	316 SS	1	
10	EYE BOLT	A105	1	6"~20"
			2	24"~36"

SIZE	INCH	1-1/2	2	2-1/2	3	4	5	6	8	10	12	14	16	18	20	24	30	36
	MM	38	50	65	80	100	127	150	200	250	300	350	400	450	500	600	762	915
A	INCH	-	4.37	5.13	5.88	7.64	9.38	10.5	12.64	15.75	18.0	19.38	22.25	24.13	26.88	31.14	-	-
	MM	-	111	130	149	194	238	267	321	400	457	492	565	613	683	791	-	-
B	INCH	-	2.37	2.87	3.5	4.5	5.56	6.62	8.62	10.75	12.75	14.0	16.0	18.0	20.0	24.0	-	-
	MM	-	60	73	89	114	141	168	219	274	324	356	406	457	508	610	-	-
C	INCH	-	2.36	2.64	2.87	3.11	4.13	5.35	6.5	8.39	9.0	10.75	12.0	14.25	14.5	17.25	-	-
	MM	-	60	67	73	79	105	136	165	213	229	273	305	362	368	438	-	-
WGT	LBS	-	6	11	11	22	50	62	113	210	290	455	640	850	1120	2040	-	-
	KGS	-	2.7	5	5	10	23	28	51	95	132	206	290	386	508	925	-	-

